

Acme Pumps

Type VL Vertical In-Line
Centrifugal Pumps



16 bar working pressure. Excellent parts interchangeability.

Description

Acme type VL Vertical In-Line Centrifugal Pumps are of single-stage design suitable for handling water, chemicals and other liquids. They are available in Cast Iron and a range of corrosion resistant stainless steel. They are widely used in building services, water supply and treatment, sprinkling, drainage, liquid transfer, food, chemical and other general industrial applications.

Features

- **16 bar working pressure** as standard with optional casing for a working pressure of up to 20 bar requires robust and solid construction to ensure durability even under high suction pressure.
- **Double volute design** available for selected pumps. It eliminates radial load by balancing the hydraulic force of liquid within the pump casing, extends seal and bearing life and minimizes vibration and noise.
- **DIN 2533 ND/16** suction and delivery flange connections to meet the design working pressure rating.
- **Vertical In-Line design** saves floor space. Both suction and discharge nozzles are having the same size and provide for easy installation.
- **Excellent parts interchangeability** reduces inventory level for spare parts.

Material Specification

Part	Standard	Stainless Steel*
Casing	Cast Iron	Stainless Steel
Impeller	Stainless Steel	Stainless Steel
Shaft	Stainless Steel	Stainless Steel
Stuffing Box	Mechanical Seal	Mechanical Seal

* Available in Stainless Steel 304, 316, 316L and Duplex Stainless Steel.

Operating Limits

Working Pressure	Test Pressure	Suction Pressure	Max. Liquid Temperature
16 bar	24 bar	Up to 16 bar	110° C

Construction

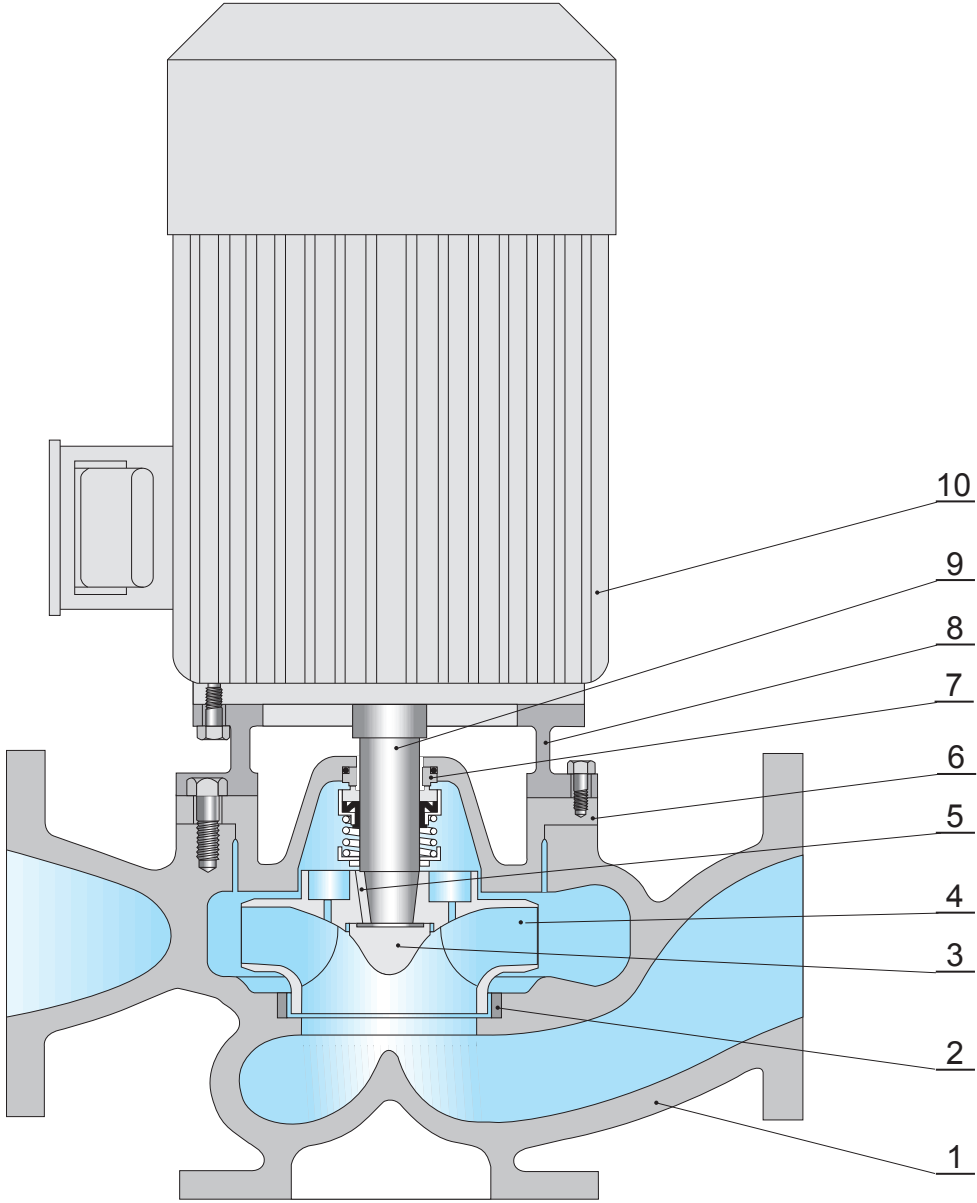

-
- | | |
|-----------------------|-------------------|
| 1 Pump Casing | 6 Stuffing Box |
| 2 Wear Ring(optional) | 7 Mechanical Seal |
| 3 Impeller Nut | 8 Adapter |
| 4 Impeller | 9 Shaft |
| 5 Impeller Key | 10 Motor |

Coverage Charts

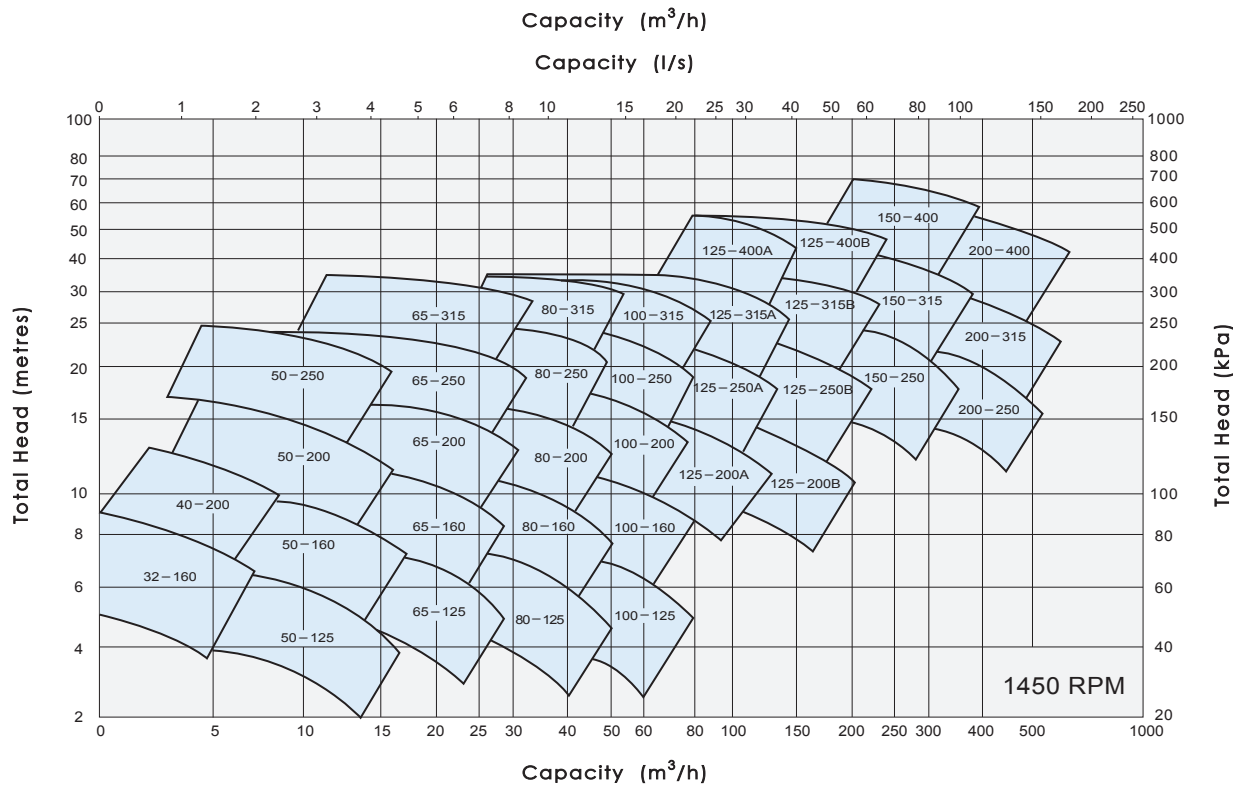
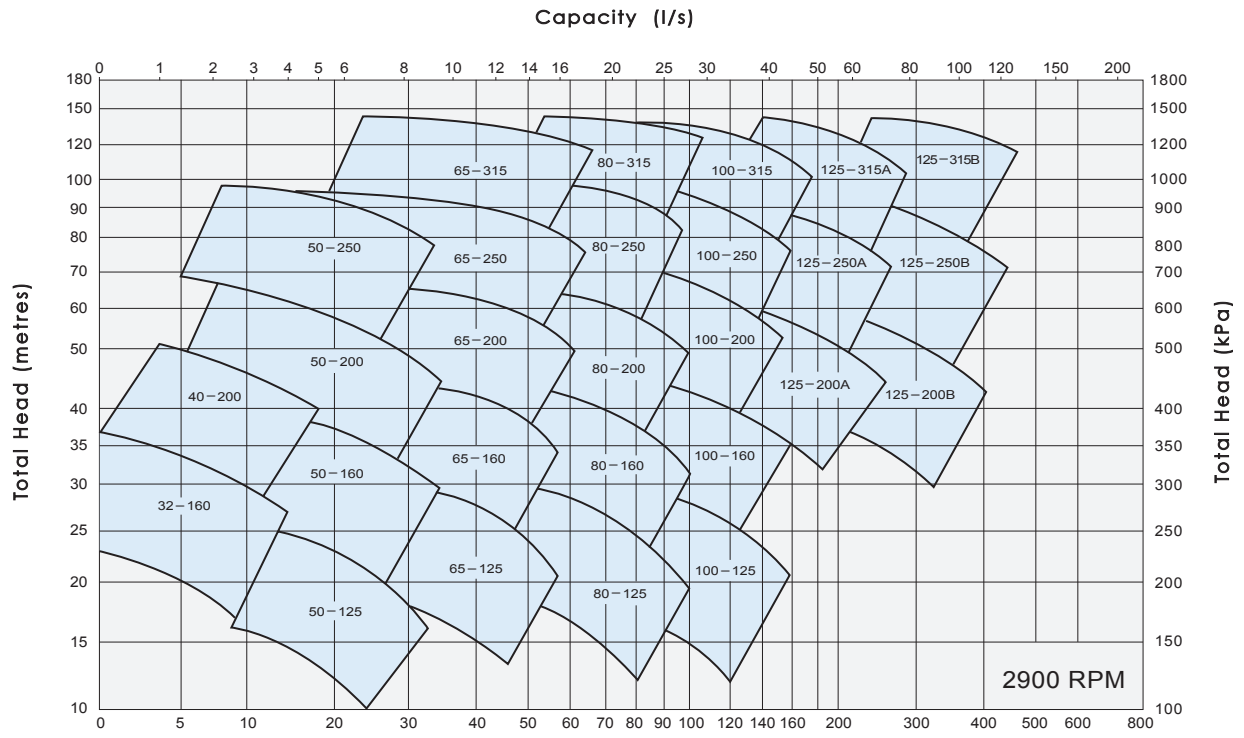

We reserve the right to amend designs without notice.

Acme Pumps Inc,
 Denville, New Jersey 07834,
 U.S.A.
 Tel: (973) 3359686
 Fax: (973) 3359624

Distributor: